

Tutorial on Deep Learning for Natural Language Processing
ICON-2017, Jadavpur University, Kolkata, India.

Question Answering

Md Shad Akhtar

Research Scholar

AI-NLP-ML Group

Department of Computer Science & Engineering

Indian Institute of Technology Patna

shad.pcs15@iitp.ac.in

<https://iitp.ac.in/~shad.pcs15/>

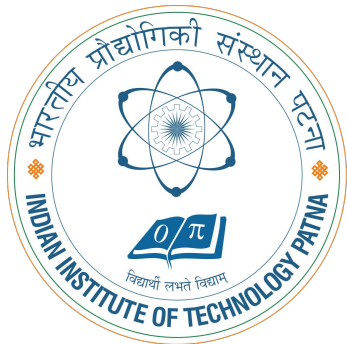

Thanks to *Deepak Gupta*,
Research Scholar, IIT Patna

Question Answering

- System that automatically answer questions posed by humans in natural language.

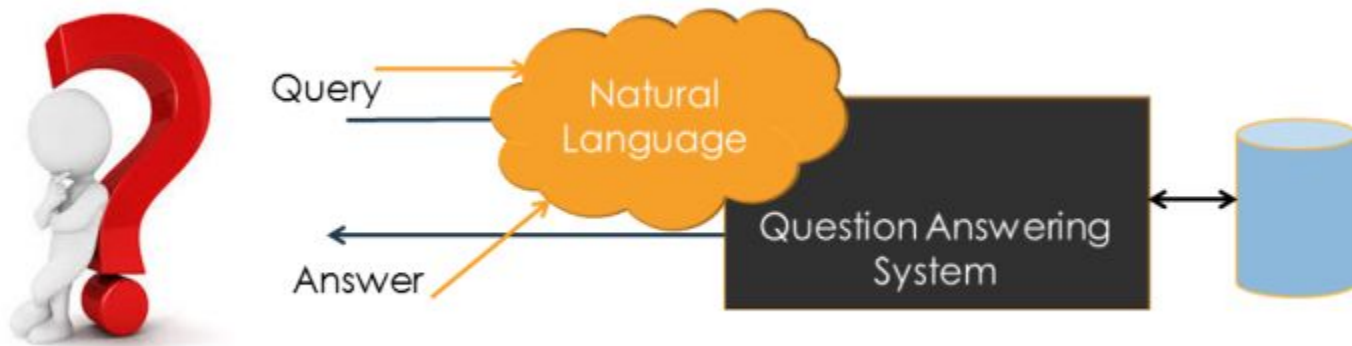

Why Question Answering?

- Conversational Agents
 - Ask it questions. Tell it to do things. Facebook (M), Apple (Siri), Google Assistant
- Biomedical and clinical QA
 - There is a need of system that accepts the queries from medical practitioners in natural language and returns the answers quickly and efficiently.
- E-commerce sites
 - E-commerce sites can exploit the user reviews to provide the answers of various user questions.

Categories of QA

- Factoid Questions
 - Question that can be answered with simple facts expressed in short text answers.
 - **Question:** *Who is the author of the book Wings of Fire?*
 - **Answer:** *A. P. J, Abdul Kalam*
- List Questions
 - Question requires multiple facts to be returned in answer to a question.
 - **Question:** *What are the islands in India?*
 - **Answer:** *Andaman Island, Nicobar Island, Labyrinth Island, Barren Island*
- Descriptive Questions
 - The answer can be short descriptive from a single sentence to multiple but limited (2-3) sentences. It can also be the long descriptive where answer can be a paragraph with meaning full information of the natural language query.
 - **Question:** *What is Greenhouse effect?*
 - **Answer:** *The analogy used to describe the ability of gases in the atmosphere to absorb heat from the earth's surface.*

A typical IR based QA

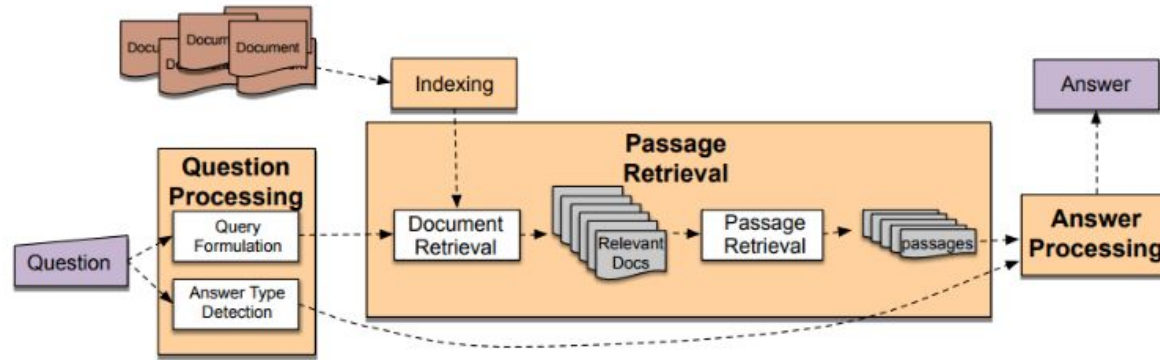

- Question Processing
 - Type of entity the answer should consists of (person, location, time, etc.).
 - The query specifies the keywords that should be used for the IR system to use in searching
- Passage Retrieval
 - Collect the document against the query for documents.
- Answer Processing
 - To extract a specific answer from the passage.
 - Use information about the expected answer type to find the answer

Sub-problems of QA

- Semantic Question matching

- Given a natural language question Q and set of candidate questions CQ , the task is to rank each of the question $Q_{cq} \in CQ$ according to their semantic similarity to the question Q ,
 - *Q1: What are the best ways to lose weight?*
 - *Q2: How can a person reduce weight?*
 - *Q3: What are the effective weight loss plans?*

- Answer Triggering

- Given a question and a set of answer candidates, **answer triggering** determines if the candidate set contains any correct answers. If yes, it then outputs a correct one.
 - *Q: How big is BMC software in houston?*
 - *A1: BMC Software Inc. is an American company specializing in Business Service Management (BSM) software.*
 - *A2: Employing over 6,000, BMC is often credited with pioneering the BSM concept as a way to help better align IT operations with business needs.*

Problem formulation: Semantic Question Matching / Answer Triggering

- Let
 - Question is q
 - Candidate questions are $CQ = \{cq_1, cq_2, \dots, cq_n\}$
 - Candidate answers are $CA = \{ca_1, ca_2, \dots, ca_n\}$
- Question - Question pairing
 - $\langle q, cq_1 \rangle, \langle q, cq_2 \rangle, \dots, \langle q, cq_n \rangle$
- Question - Answer pairing
 - $\langle q, ca_1 \rangle, \langle q, ca_2 \rangle, \dots, \langle q, ca_n \rangle$
- Decision
 - Binary - Yes/No
 - Similarity score - a continuous value in the range 0 to 1.

Detecting Duplicate Questions with Deep Learning - Siamese Network

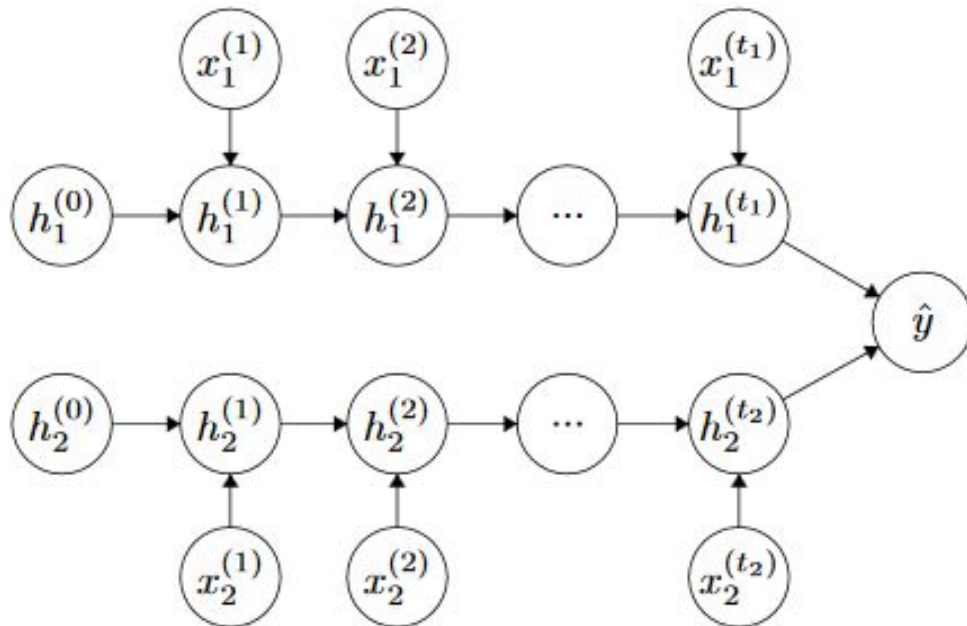

Learning Hybrid Representations to Retrieve Semantically Equivalent Questions

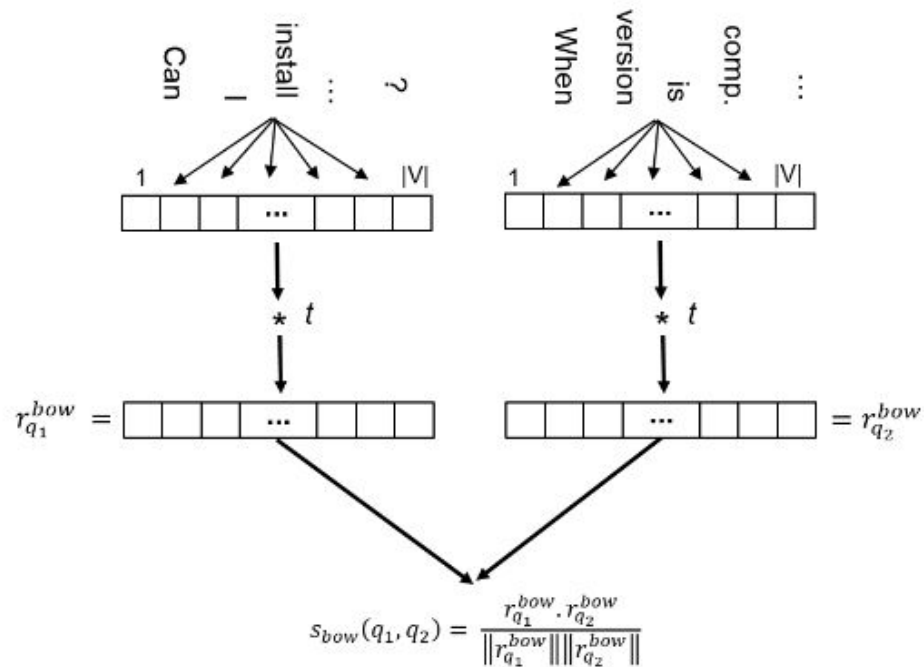
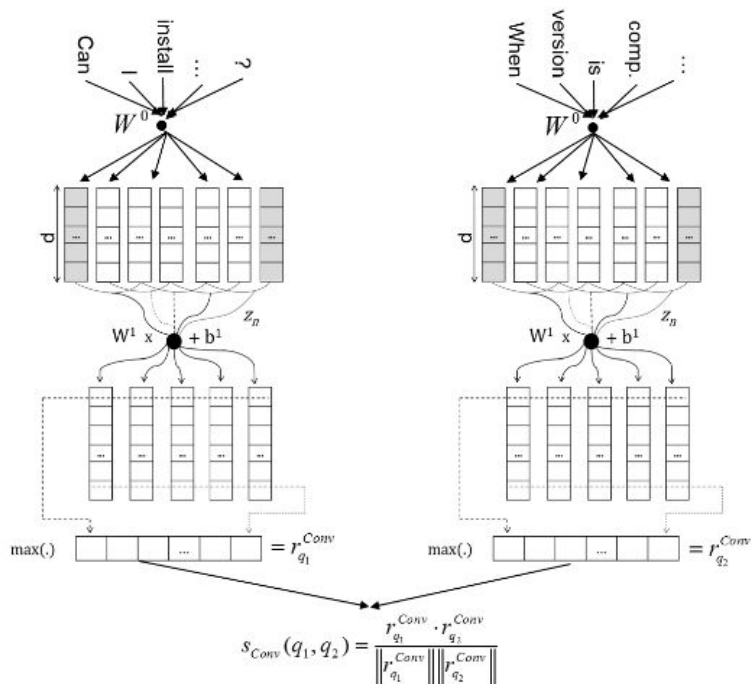

Learning Hybrid Representations to Retrieve Semantically Equivalent Questions

$$s_{bow}(q_1, q_2) = \frac{r_{q_1}^{bow} \cdot r_{q_2}^{bow}}{\|r_{q_1}^{bow}\| \|r_{q_2}^{bow}\|}$$

$$s_{conv}(q_1, q_2) = \frac{r_{q_1}^{conv} \cdot r_{q_2}^{conv}}{\|r_{q_1}^{conv}\| \|r_{q_2}^{conv}\|}$$

$$s(q_1, q_2) = \beta_1 * s_{bow}(q_1, q_2) + \beta_2 * s_{conv}(q_1, q_2)$$

SelQA: A New Benchmark for Selection-based Question Answering

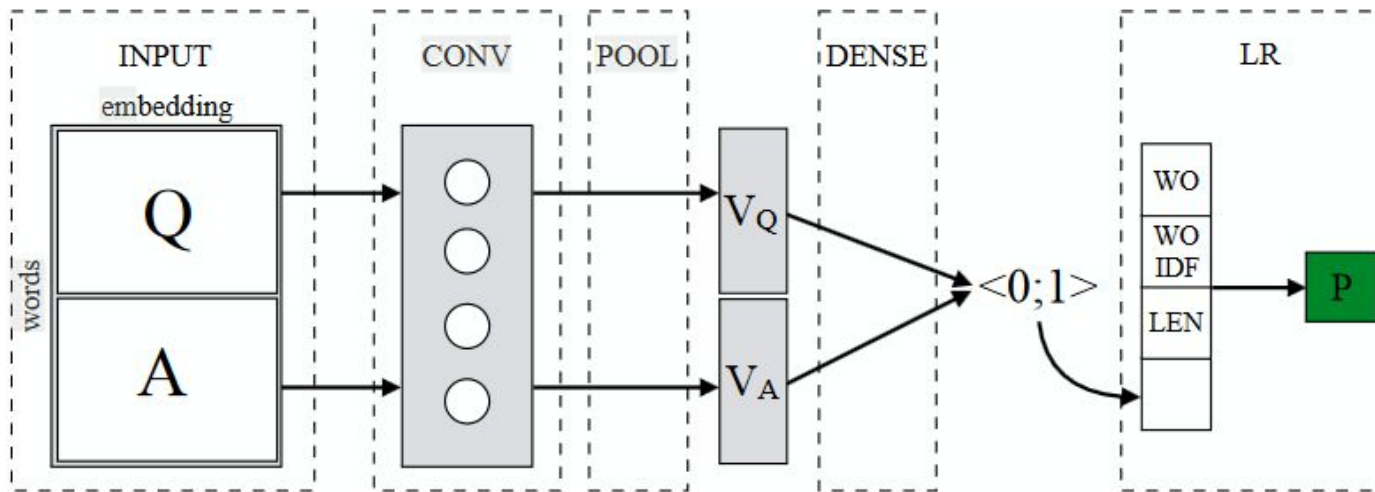

SelQA: A New Benchmark for Selection-based Question Answering

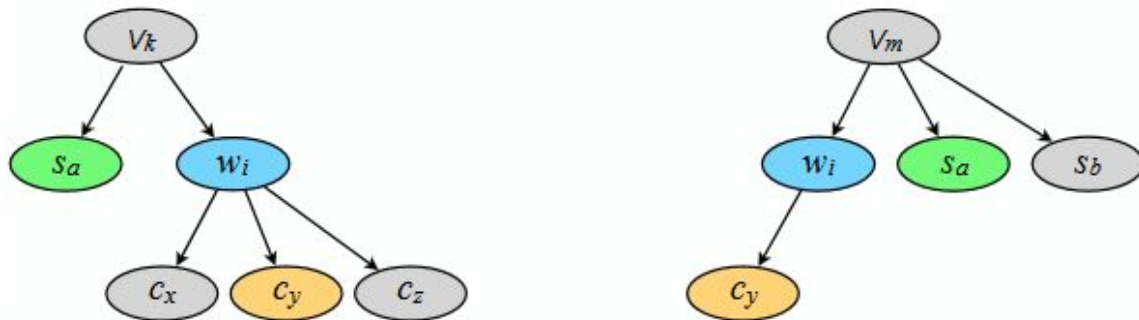

- For all $w \in T$, where T is common words in Q & A.
 - P_q & $P_a \rightarrow$ parents of w in D_q & D_a
 - S_q & $S_a \rightarrow$ siblings of w in D_q & D_a
 - C_q & $C_a \rightarrow$ children of w in D_q & D_a
- Three features: $f(P_q, P_a)$, $f(S_q, S_a)$ and $f(C_q, C_a)$

Thank You!

AI-NLP-ML Group, Department of CSE, IIT Patna (<http://www.iitp.ac.in/~ai-nlp-ml/>)

Research Supervisors:

- Prof. Pushpak Bhattacharyya
- Dr. Asif Ekbal
- Dr. Sriparna Saha